

# CLARIS GEN2 3/8" QCF HEAD

Designed exclusively for use with Claris replacement cartridgements

Claris Gen2 3/8" QCF Head: EV4339-92



## Applications

Coffee and Espresso  
Hot Drink Vending  
Combi Steamers and Self-Cooking Systems  
Steam Cookers and Ovens  
Brewed Iced Tea

## Features • Benefits

Commercial-quality filter head is designed exclusively to fit Claris filter cartridges  
Solid, durable construction is ideal for foodservice and vending applications  
Engineered for durability, strength and longevity  
Corrosion-resistant hardware  
Tamper proof bypass settings

HEAD FEATURES:  
Fast change-out - locks with only a 45° turn  
Built-in flush port  
Auto shut-off  
Quick and easy adjustable bypass; key provided

## Installation tips

The system can be operated freestanding, lying horizontally or mounted vertically.

If mounted vertically to a wall, securely connect the mounting bracket to the wall using suitable screws.

Water pressure at the filter system inlet must not exceed 116 psi (8 bar). A pressure reducer valve must be installed on the water supply side of the filter system if the inlet pressure exceeds 116 psi (8 bar).

Shut-off valve must be installed upstream of the filter.

Refer to Installation, Operation & Maintenance Manual for cartridge flushing and startup.

## Operation tips

Change Claris Cartridge when its pre-calculated water volume has been reached or at least once a year.

Change cartridges when capacity is reached.

Always flush the filter cartridge at time of installation and cartridge change.

Do not use hardness test strips to check for hardness reduction, please use titration kit to check for hardness reduction.

# CLARIS GEN2 3/8" QCF HEAD

EV4339-92

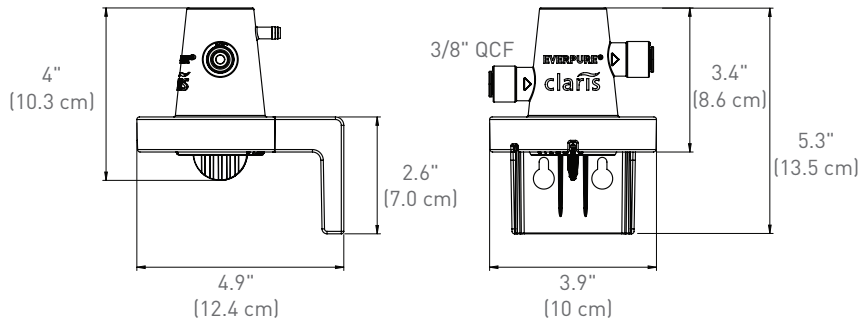

## Specifications

Overall Dimensions:  
5.3" H x 3.9" W x 4.9" D  
(13.5 cm x 10 cm x 12.4 cm)

Electrical Connection:  
None required

Claris™ is a trademark of Aquis, GmbH

## Warranty

Everpure Claris water treatment systems by Pentair® are covered by a limited warranty against defects in material and workmanship for a period of one year after date of purchase. Everpure replaceable elements (filter cartridges and water treatment cartridges) are covered by a limited warranty against defects in material and workmanship for a period of one year after date of purchase. See printed warranty for details. Pentair will provide a copy of the warranty upon request.



## Pentair Offices in South East Asia

### Singapore

390 Havelock Road  
#04-01 King's Centre  
Singapore 169662  
Tel: +6567685900

### Thailand

16th Floor, The Ninth Towers  
Grand RAMA 9, Tower B  
33/4 Rama 9 Road, Huaykwang  
Bangkok 10310, Thailand  
Tel: +6621681092

### Philippines

5th Floor MAIA Suites  
1747 Nicanor Garcia Street corner  
D.Oliman Street Makati City, Philippines  
Tel: +632824 3825

All Pentair trademarks and logos are owned by Pentair. All other brands or product names are trademarks or registered marks of their respective owners. Because we are continuously improving our products and services. Pentair reserves the right to change specifications without prior notice. Pentair is an equal opportunity employer.  
©2022 Pentair. All Rights Reserved.